

6.25Gbs 1310nm Single-mode SFP+ Transceiver (2km)

PRODUCT FEATURES

- Up to 2km transmission distance
- FP transmitter and PIN photo-detector
- Duplex LC connector
- Metal enclosure, for lower EMI
- Electrical interface compliant to SFF-8431 specifications
- 2-wire interface for management specifications compliant with SFF-8472
- Single 3.3V power supply
- Case operating temperature range: 0°C to +70°C

APPLICATIONS

- High-speed storage area networks
- OBSAI and CPRI
- LTE optical repeater application

I . Absolute Maximum Ratings

Parameter	Symbol	Min	Typ	Max	Unit	NOTE
Maximum Supply Voltage	Vcc	3.15		3.46	V	
Storage Temperature	Ts	-40		85	°C	

Case Operating Temperature	Tcase	0		70	°C	
----------------------------	-------	---	--	----	----	--

II. Electrical Characteristics

Parameter	Symbol	Min	Typ	Max	Unit	NOTE
Supply Voltage	Vcc	3.15	3.3	3.46	V	
Supply Current	Icc			360	mA	
Transmitter						
Input differential impedance	Rin		100		Ω	1
Single ended data input swing	Vin,pp	180		600	mV	
Transmit Disable Voltage	VD	Vcc-1.3		Vcc	V	
Transmit Enable Voltage	VEN	Vee		Vee+ 0.8	V	2
Transmit Disable Assert Time				10	us	
Receiver						
Differential data output swing	Vout,pp	300		850	mV	3
Data output rise time	tr	28			ps	4
Data output fall time	tf	28			ps	4
LOS Fault	VLOS fault	Vcc-1.3		VccHOST	V	5
LOS Normal	VLOS norm	Vee		Vee+0.8	V	5
Power Supply Rejection	PSR	100			mVpp	6

Notes:

1. Connected directly to TX data input pins. AC coupled thereafter.
2. Or open circuit.
3. Into 100 ohms differential termination.
4. 20 – 80 % Measured with Module Compliance Test Board and OMA test pattern.
5. Loss Of Signal is LVTTTL. Logic 0 indicates normal operation; logic 1 indicates no signal detected.
6. Receiver sensitivity is compliant with power supply sinusoidal modulation of 20 Hz to 1.5 MHz up to specified value applied through the recommended power supply filtering network.

III . Optical Characteristics

Parameter	Symbol	Min	Typ	Max	Unit	NOTE
Transmitter						
Average output power	POUT	-6.5		0.5	dBm	1
Optical Wavelength	λ	1260	1310	1355	nm	
RMS Spectral Width	σ			3.5	nm	
Optical Extinction Ratio	ER	3.5			dB	

Side mode Suppression ratio	SMSR	30			dB	
RIN	RIN			-128	dB/Hz	
Transmitter Jitter (peak to peak)		IEEE 802.3.ae requirements				
Receiver						
Receiver Sensitivity	P _{sen}			-14.4	dBm	2
Input Saturation Power (Overload)	P _{SAT}	0.5			dBm	
Input Optical Wavelength	λ_C	1270		1610	nm	
LOS De -Assert	LOSD			-18	dBm	
LOS Assert	LOSA	-30			dBm	
LOS Hysteresis		0.5	1		dB	

Notes:

1. Class 1 Laser Safety per FDA/CDRH and IEC-825-1 regulations.
2. Measured with a PRBS $2^{31}-1$ test pattern, @6.25Gb/s, BER < 10^{-12} .

IV . Pin Descriptions

Pin	Symbol	Name/Description	NOTE
1	V _{EET}	Transmitter Ground (Common with Receiver Ground)	1
2	T _{FAULT}	Transmitter Fault.	2
3	T _{DIS}	Transmitter Disable. Laser output disabled on high or open.	3
4	SDA	2-wire Serial Interface Data Line	4
5	SCL	2-wire Serial Interface Clock Line	4
6	MOD_ABS	Module Absent. Grounded within the module	4
7	RS0	RS0 for Rate Select: Open or Low = Module supports 1.25 Gb/s High = Module supports 6.25 Gb/s	5
8	LOS	Loss of Signal indication. Logic 0 indicates normal operation.	6
9	RS1	No connection required	1

10	V _{EER}	Receiver Ground (Common with Transmitter Ground)	1
11	V _{EER}	Receiver Ground (Common with Transmitter Ground)	1
12	RD-	Receiver Inverted DATA out. AC Coupled	
13	RD+	Receiver Non-inverted DATA out. AC Coupled	
14	V _{EER}	Receiver Ground (Common with Transmitter Ground)	1
15	V _{CCR}	Receiver Power Supply	
16	V _{CCT}	Transmitter Power Supply	
17	V _{EET}	Transmitter Ground (Common with Receiver Ground)	1
18	TD+	Transmitter Non-Inverted DATA in. AC Coupled.	
19	TD-	Transmitter Inverted DATA in. AC Coupled.	
20	V _{EET}	Transmitter Ground (Common with Receiver Ground)	1

Notes:

1. Circuit ground is internally isolated from chassis ground.
2. TFAULT is an open collector/drain output, which should be pulled up with a 4.7k – 10k Ohms resistor on the host board if intended for use. Pull up voltage should be between 2.0V to Vcc + 0.3V. A high output indicates a transmitter fault caused by either the TX bias current or the TX output power exceeding the preset alarm thresholds. A low output indicates normal operation. In the low state, the output is pulled to <0.8V.
3. Laser output disabled on TDIS >2.0V or open, enabled on TDIS <0.8V.
4. Should be pulled up with 4.7k - 10 kohms on host board to a voltage between 2.0V and 3.6V. MOD_ABS pulls line low to indicate module is plugged in.
5. Transceiver data rate selected through the 2-wire bus in accordance with SFF-8472 Rev. 10.5. Soft RS0 is set at Bit3, Byte 110, Address A2h. Soft RS0 default state on power up is '0' LOW, and the state is reset following a power cycle. Writing '1' HIGH selects max. data rate operation. Transceiver data rate is the logic OR of the input state of the RS0 pin and soft RS0 bit. Thus, if either the RS0 pin OR the soft RS0 bit is HIGH then the selected data rate will be 6.25 Gb/s.
6. Loss Of Signal is LVTTTL. Should be pulled up with 4.7kΩ – 10kΩ on host board to a voltage between 2.0V and 3.6V. Logic 0 indicates normal operation; logic 1 indicates loss of signal.

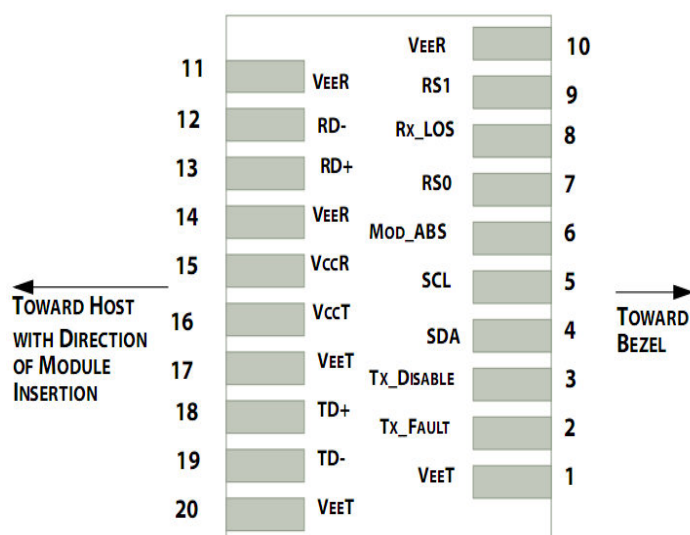
**Pinout of Connector Block on Host Board**

V . Digital Diagnostic Functions

SFP+ transceivers support the 2-wire serial communication protocol as defined in the SFP+ MSA.

The standard SFP+ serial ID provides access to identification information that describes the transceiver's capabilities, standard interfaces, manufacturer, and other information.

Additionally, SFP+ transceivers provide a unique enhanced digital diagnostic monitoring interface, which allows real-time access to device operating parameters such as transceiver temperature, laser bias current, transmitted optical power, received optical power and transceiver supply voltage. It also defines a sophisticated system of alarm and warning flags, which alerts end-users when particular operating parameters are outside of a factory set normal range.

The SFP+ MSA defines a 256-byte memory map in EEPROM that is accessible over a 2-wire serial interface at the 8 bit address 1010000X (A0h). The digital diagnostic monitoring interface makes use of the 8 bit address 1010001X (A2h), so the originally defined serial ID memory map remains unchanged.

The operating and diagnostics information is monitored and reported by a Digital Diagnostics Transceiver Controller (DDTC) inside the transceiver, which is accessed through a 2-wire serial interface. When the serial protocol is activated, the serial clock signal (SCL, Mod Def 1) is generated by the host. The positive edge clocks data into the SFP+ transceiver into those segments of the E2PROM that are not write-protected. The negative edge clocks data from the SFP+ transceiver. The serial data signal (SDA, Mod Def 2) is bi-directional for serial data transfer. The host uses SDA in conjunction with SCL to mark the start and end of serial protocol activation. The memories are organized as a series of 8-bit data words that can be addressed individually or sequentially.

VI . Host - Transceiver Interface Block Diagram

VII . Mechanical

Comply to SFF-8432 rev. 5.0, the improved Pluggable form factor specification.

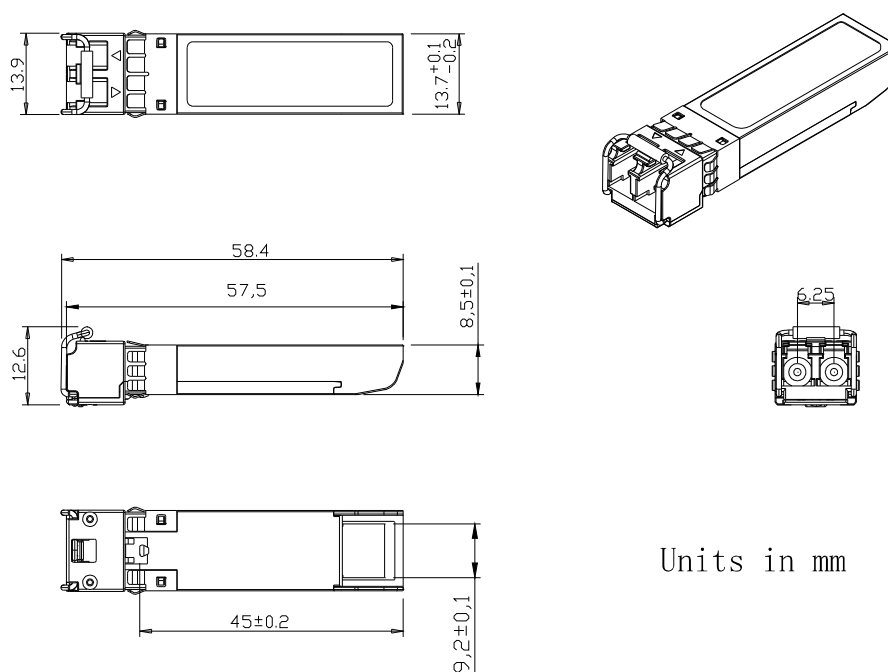

Units in mm

VIII . Regulatory Compliance

Feature	Reference	Performance
Electrostatic discharge (ESD)	IEC/EN 61000-4-2	Compatible with standards
Electromagnetic Interference (EMI)	FCC Part 15 Class B EN 55022 Class B (CISPR 22A)	Compatible with standards
Laser Eye Safety	FDA 21CFR 1040.10, 1040.11 IEC/EN 60825-1 , 2	Class 1 laser product
Component Recognition	IEC/EN 60950 , UL	Compatible with standards
ROHS	2002/95/EC	Compatible with standards
EMC	EN61000-3	Compatible with standards

Appendix A. Document Revision

Version No.	Date	Description
1.0	2012-09-01	Preliminary datasheet